

Virtual Bridge Port Extension

Bridge Port Extension (IEEE P802.1Qbh)

René Raeber

Datacenter Architect Cisco

rraeber@cisco.com / rraeber@ieee.org

Introduction

- P802.1Qbh specifies three major items:
 - A Port Extender
 - An M-Component which is used to make a Port Extender
 - A EVB Controlling Bridge, a bridge that is capable of being extended using Port Extenders
- The combination of the EVB Controlling Bridge and the Port Extenders is referred to as an Extended VLAN Bridge (E-VLAN Bridge)
- Some assumptions:
 - The Port Extender Configuration and Status Protocol operates over ECP
 - The VSI discovery protocol operates through Port Extenders transparently
 - The Channel Discovery and Configuration Protocol operates over LLDP using the nearest non-TPMR address
 - Therefore, the CDCP is terminated by a Port Extender at the edge of an Extended Bridge and translated into the appropriate PE CSP command (S-channel create)
 - Likewise, the edge Port Extender is responsible for initiating the CDCP LLDP frames based on its current S-channel configuration
 - LLDP frames addressed to nearest customer bridge (e.g. VSI discovery) pass transparently through the Port Extenders to the C-VLAN component within the controlling bridge

Port Extension Capabilities

- Port Extenders may be cascaded
- Port Extenders simplify management
 - Reduces total number of switches in network
 - Enables advanced capability of higher level switches
 - Provides reliable indication of source / destination VNIC
- Port Extenders may connect to other switches or end stations
- Port Extenders perform local replication of multicast and flooded frames

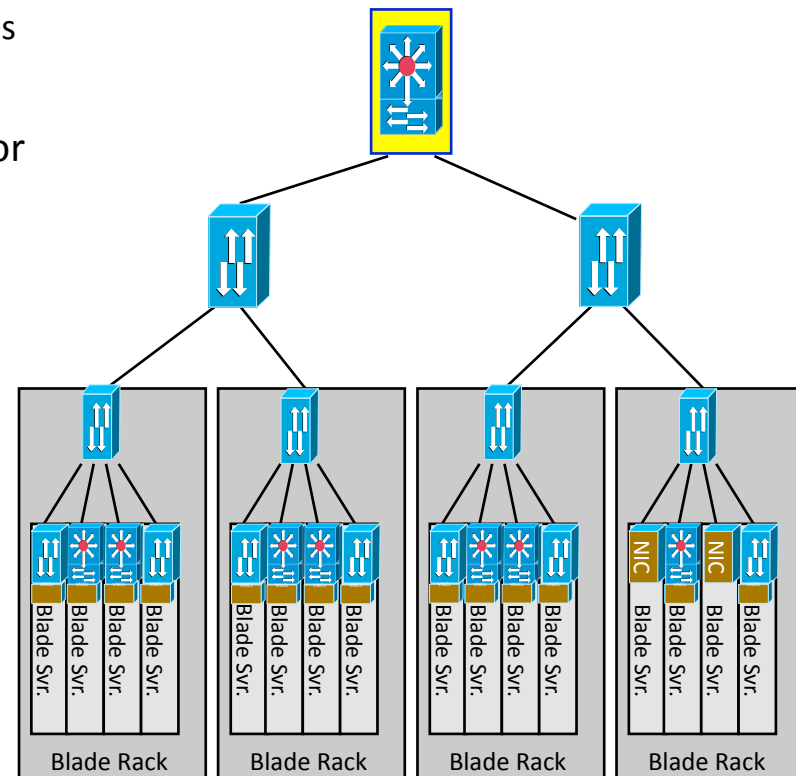
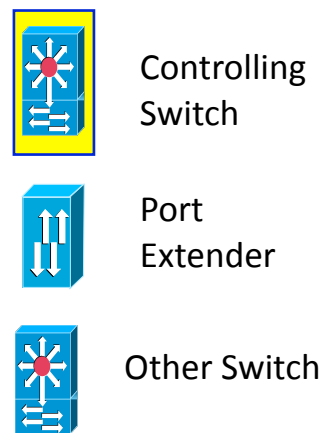

Port Extension Capabilities

- Port Extenders simplified network topology and therefore network management

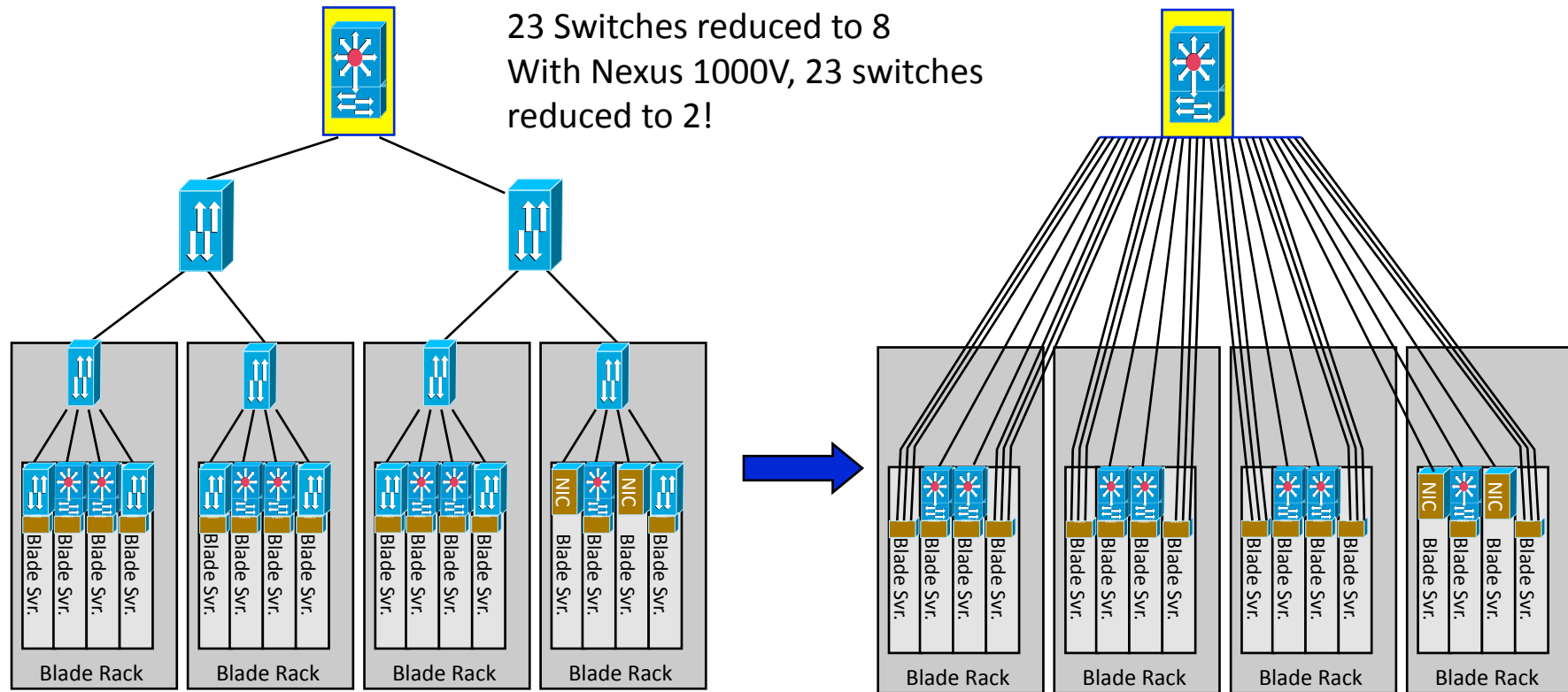

How it works

- Port Extension standardizes a new tag and a new use of an existing tag
 - On ingress, an S-TAG provides a reliable indication of the ingress port
 - On egress, an S-TAG enables the Controlling Switch to explicitly specify an egress port
 - Or an M-TAG enables the Controlling Switch to explicitly specify a group of egress ports for multicast or flooded frames

The M-TAG

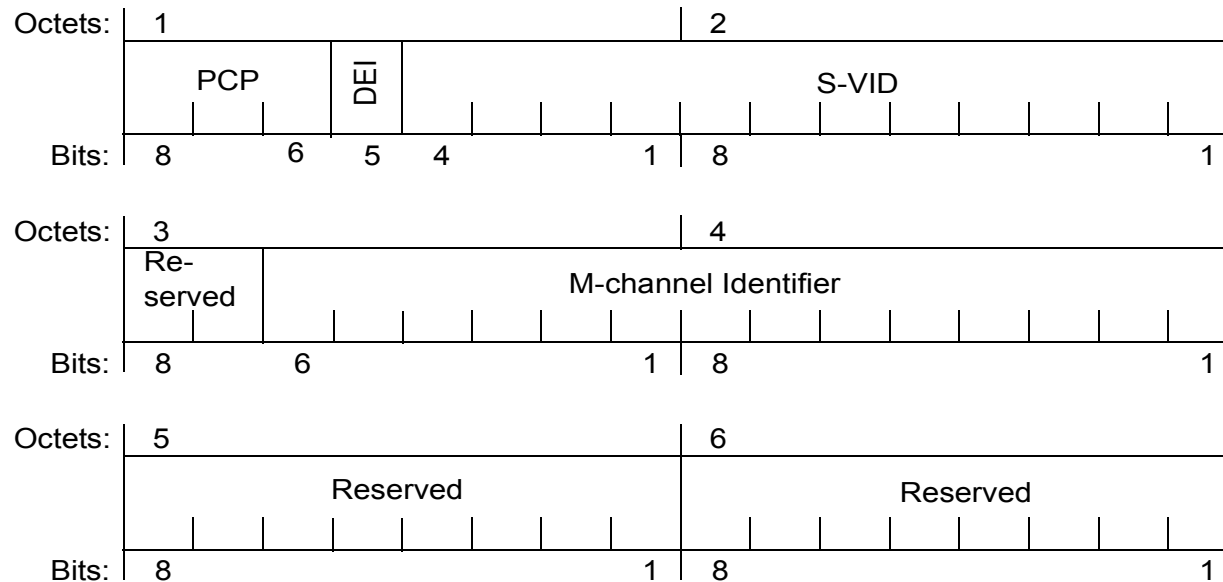

- DEI and PCP used for traffic class selection
- S-VID contains the identifier of the Port Extender Port that sourced this frame
 - Port Extender filters the frame from this port
- M-channel Identifier selects a group of ports to which this frame is to be replicated

Late Breaking News:

- Both Qbg and Qbh “borrow” the S-Tag from Provider Bridging
- Provider Bridging technology is becoming more popular in the Data Center for use in VLAN scalability
 - This does not work with Qbg and Qbh because of the tag usage conflict
- The members of IEEE have expressed a strong interest in enabling Qbh to operate in any bridge environment, including Provider Bridge Environments
 - This will probably result in the elimination of the use of S-Tag in Qbh. Instead, the M-Tag will be used for both multicast and unicast.
- No interest expressed in expanding Qbg. It will be limited to the extreme edge of a virtualized customer bridge environment.

Use of Text Color

- Green text indicates an action operating over LLDP using the nearest customer bridge address
- Brown text indicates an action operating over LLDP using the nearest non-TPMR address
- Blue text indicates an action using the Port Extender Control and Status Protocol (which may use unicast addresses or a well known multicast address, TBD).

E-VLAN Bridge Model of Operation

- In the beginning...
 - For example, a two port bridge

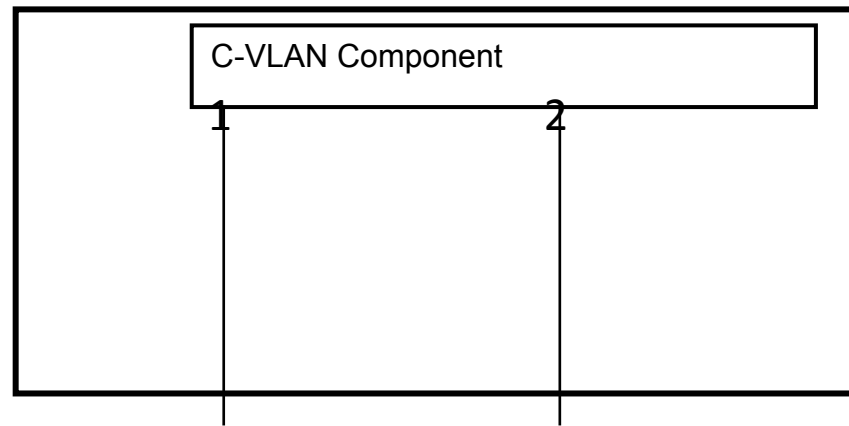

E-VLAN Bridge Model of Operation

- The Universe is created...
 - A Port Extender and an end device are attached
 - The PMSC is instantiated and the C-VLAN component ports 1 & 2 come up
 - LLDP starts executing on CVC ports 1&2
 - Port Extender discovered on port 1
 - Something else discovered on port 2
 - EVB Control and Status Protocol (EVB CSP) starts executing on CVC Port 1
 - Configures member set and untagged set on PE.
 - Configures PE Uplink port parameters (PFC, ETS, etc.)

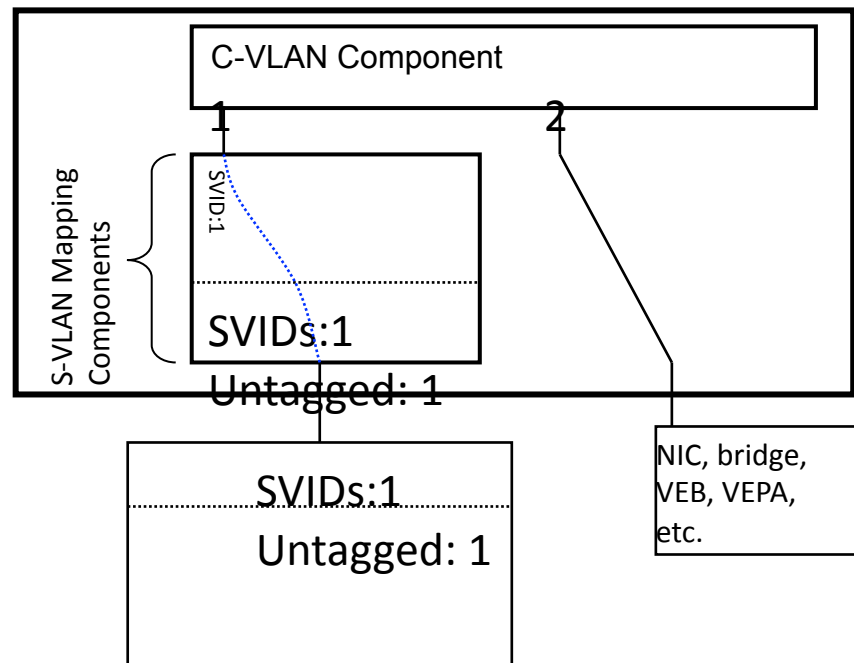

E-VLAN Bridge Model of Operation

- The Universe Expands...
 - The EVB Controlling Bridge discovers via the PE CSP that the PE has two ports active
 - C-VLAN component ports 3 & 4 instantiated
 - PMSC SVID member sets and untagged sets set-up
 - Downlink port parameters Configured (PFC, ETS, etc.)
 - The C-VLAN Component starts executing LLDP on ports 3 & 4.

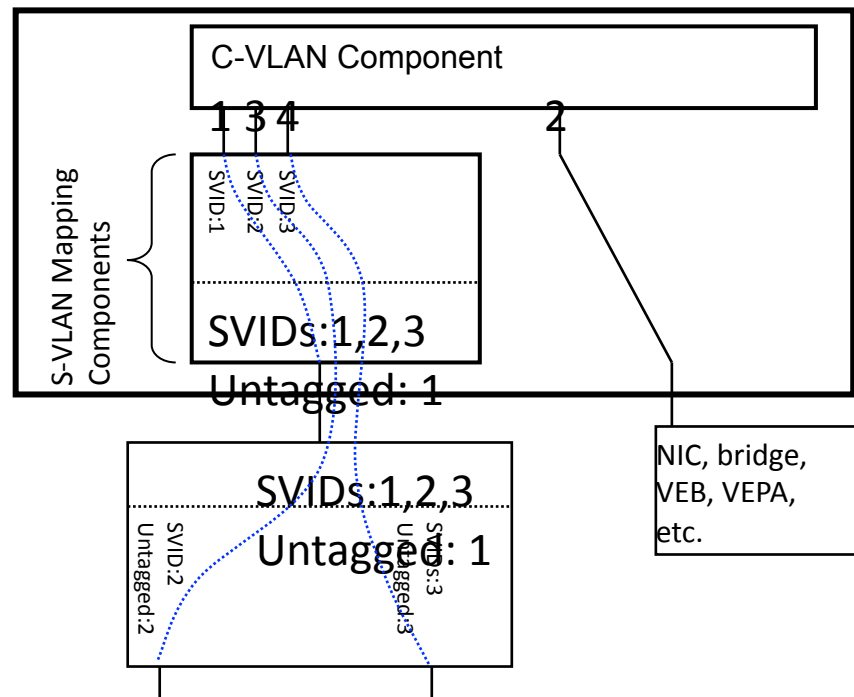

E-VLAN Bridge Model of Operation

- The Universe Expands Some More...

–LLDP on CVC port 3 discovers something other than a PE.

–LLDP on CVC port 4 discovers the second PE.

–EVB CSP Protocol starts executing on CVC port 4

- Configures second PE Uplink member sets, untagged sets, and port parameters.

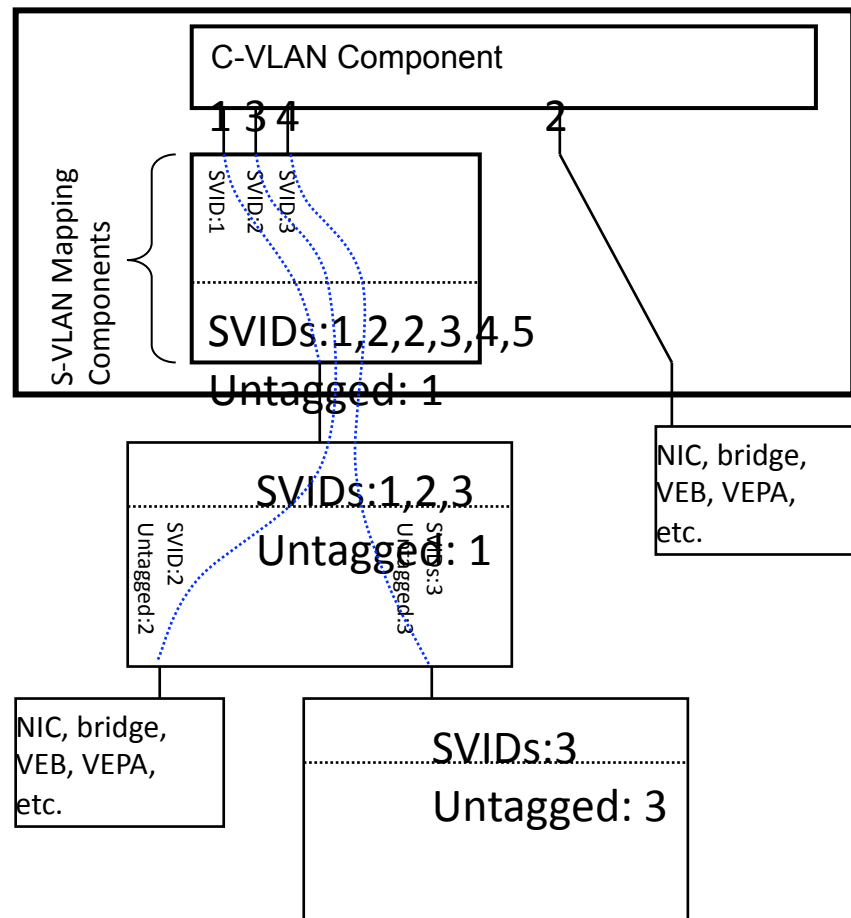

E-VLAN Bridge Model of Operation

- The Universe Expands Even More...
 - EVB CSP on C-VLAN component port 3 discovers two ports on the second PE.
 - CVC ports 5 & 6 instantiated
 - EVB CSP sets up member sets and untagged sets in PE Ports
 - LLDP on CVC port 5 & 6 discovers something other than a PE.
- See next slide for the Multichannel Configuration

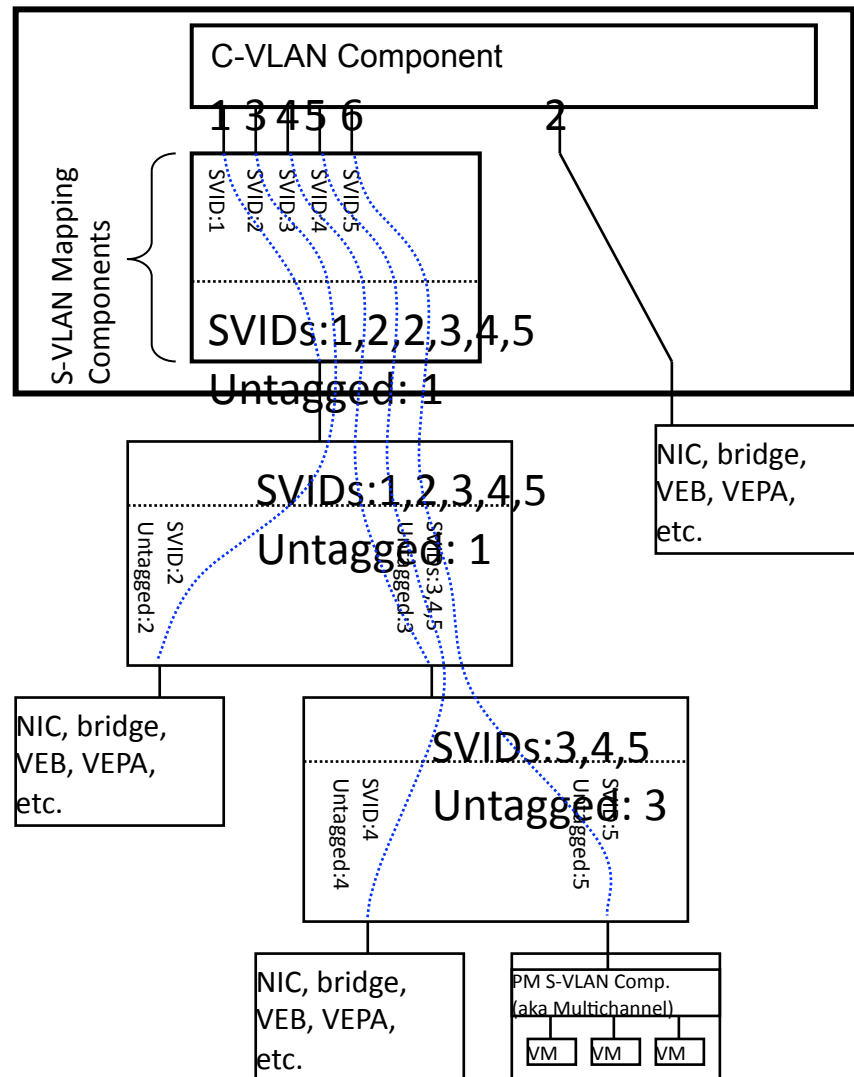

E-VLAN Bridge Model of Operation

- The Multichannel is configured:
 - CDCP (nearest non-TPMR LLDP) propose takes place between the PMSC and the bottom PE
 - Bottom PE issues a S-channel create CSP message.
 - Controlling Bridge issues an S-channel create CSP message to the top PE and waits for the response
 - Controlling Bridge issues an S-channel response message to the bottom PE
 - Bottom PE initiates sending of CDCP frames which acknowledges the proposal
 - PMSC configures the multichannel

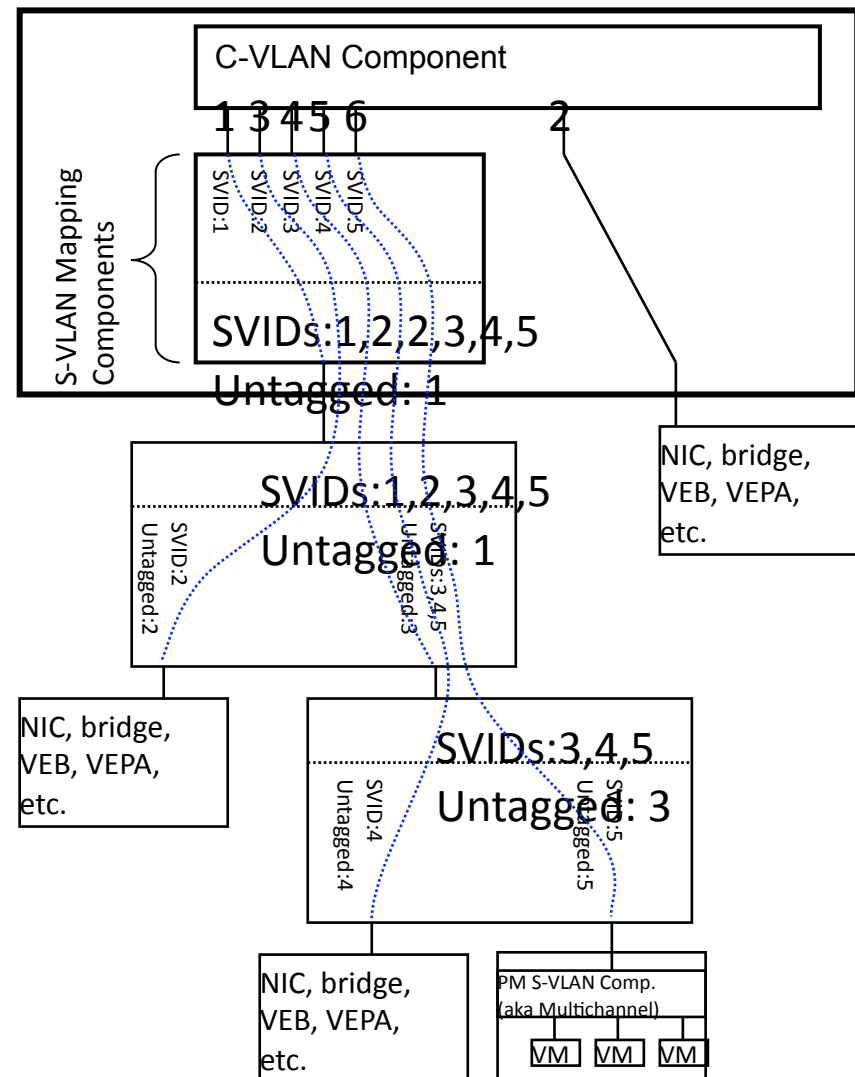

A Ladder Diagram

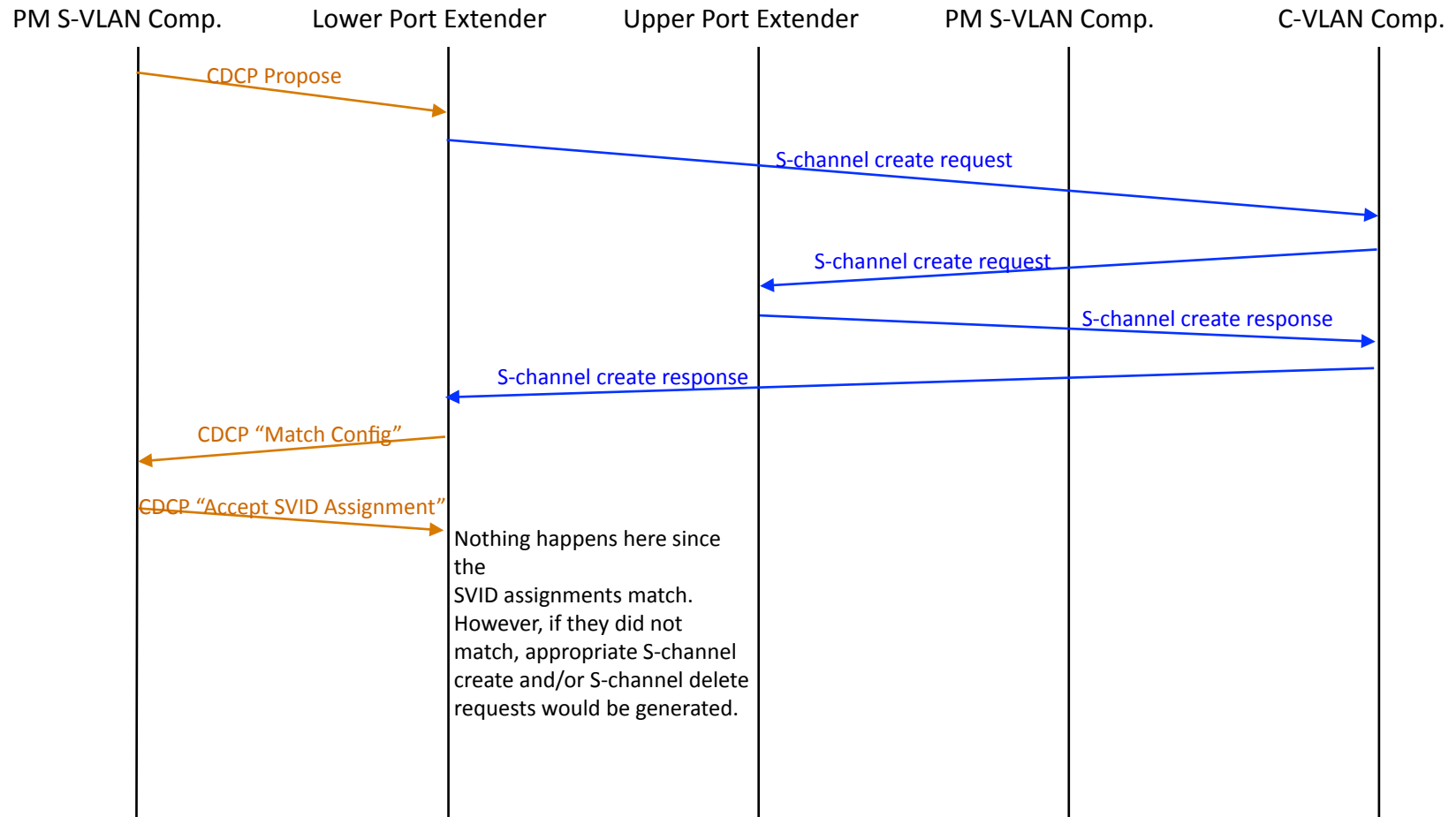

E-VLAN Bridge Model of Operation

- The Universe Expands Just a Little Bit More...

–(I need another PE to make my multicast examples interesting ;-)

–**EVB CSP** and **LLDP** operate as previously described

- Details left as an exercise to the reader

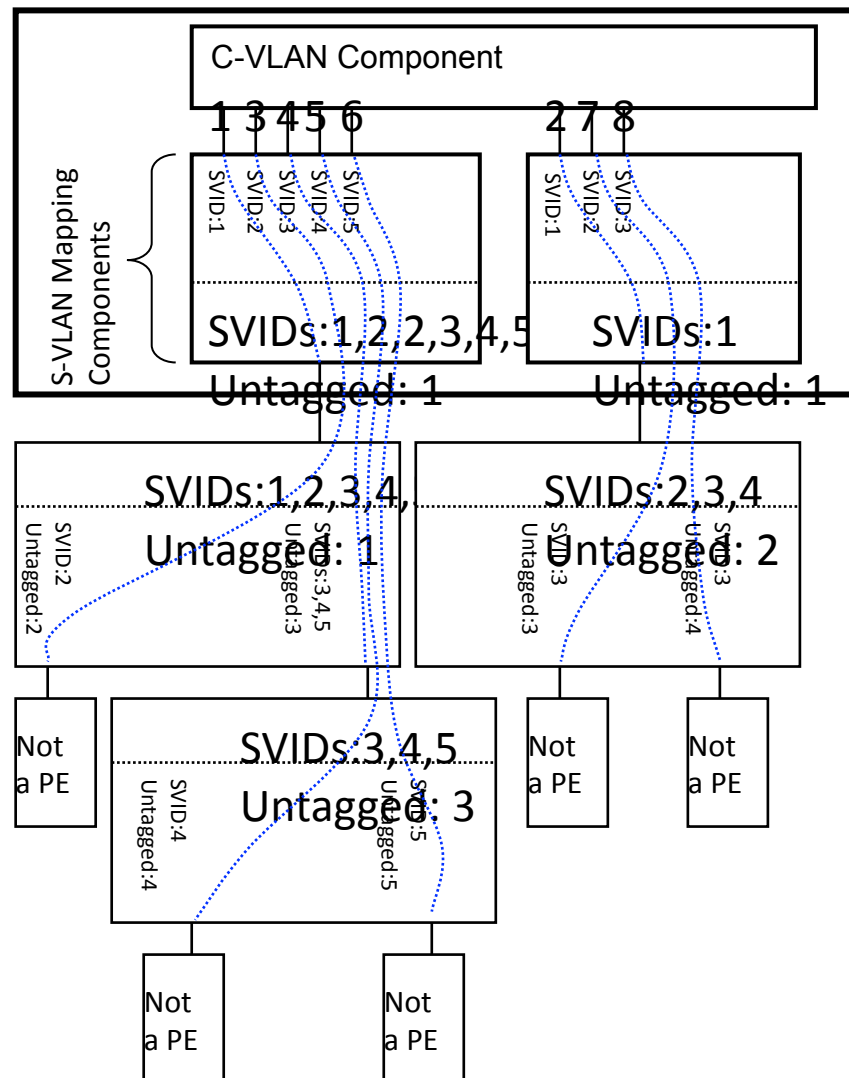

E-VLAN Bridge Model of Operation

- A Multicast Example...
 1. Multicast frame originated (no S-TAG)
 2. PE adds S-TAG with SVID 5
 3. SVID Still 5
 4. S-TAG removed, frame received on CVC port 6
 5. Without remote replication, frame would be forwarded on CVC ports 3 & 5. With remote replication, frame forward to Primary PE port with M-TAG; filter set true, source SVID set to 5.
 6. Frame could be sent to CVC port 8, but we'll keep this a multicast example. So, frame is M-Tagged with filter set false and SVID set to 0.
 7. Frame forwarded with M-TAG and no S-TAG
 8. PE does replication. M-TAG removed since this is the last PE.
 9. Frame has M-TAG and no S-TAG.
 10. M-TAG removed since this is the last PE
 11. PE filters frame since this is the last PE, filter set TRUE, and SVID matches source SVID in M-TAG.
 12. Frame forwarded with M-TAG and no S-TAG
 13. M-TAG removed since last PE

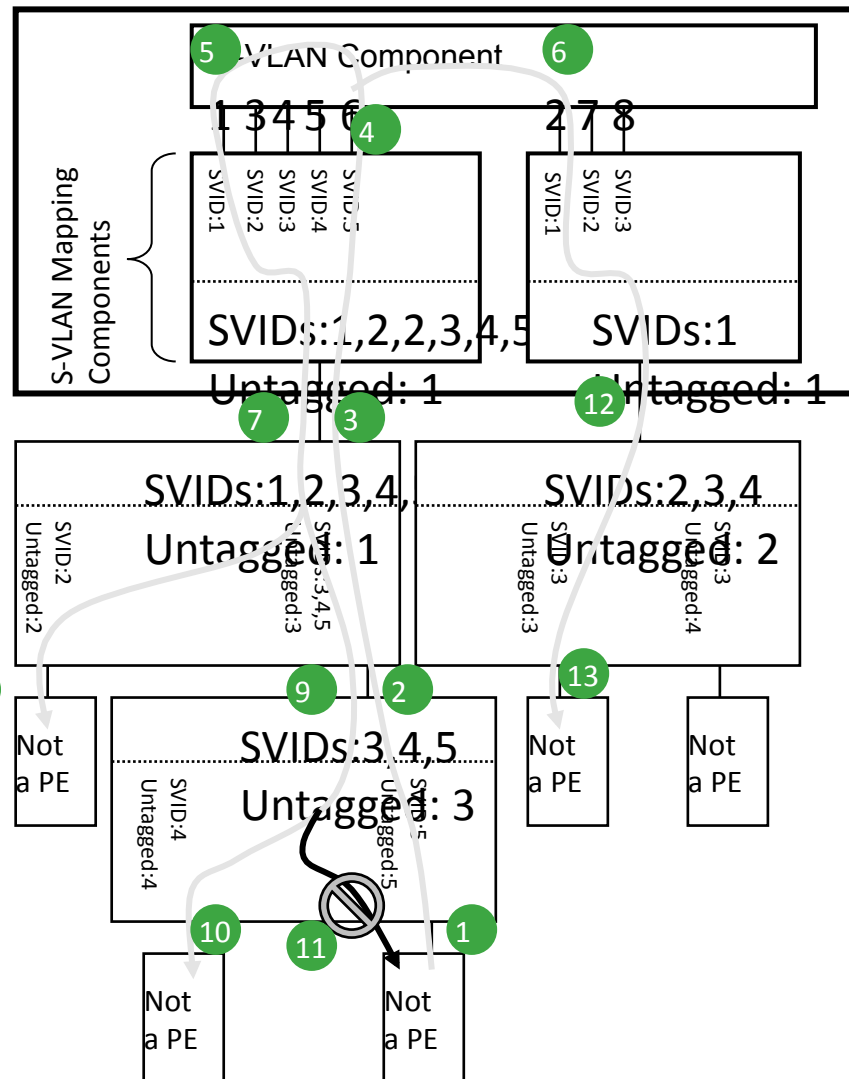

Controlling Switch & PE Architecture

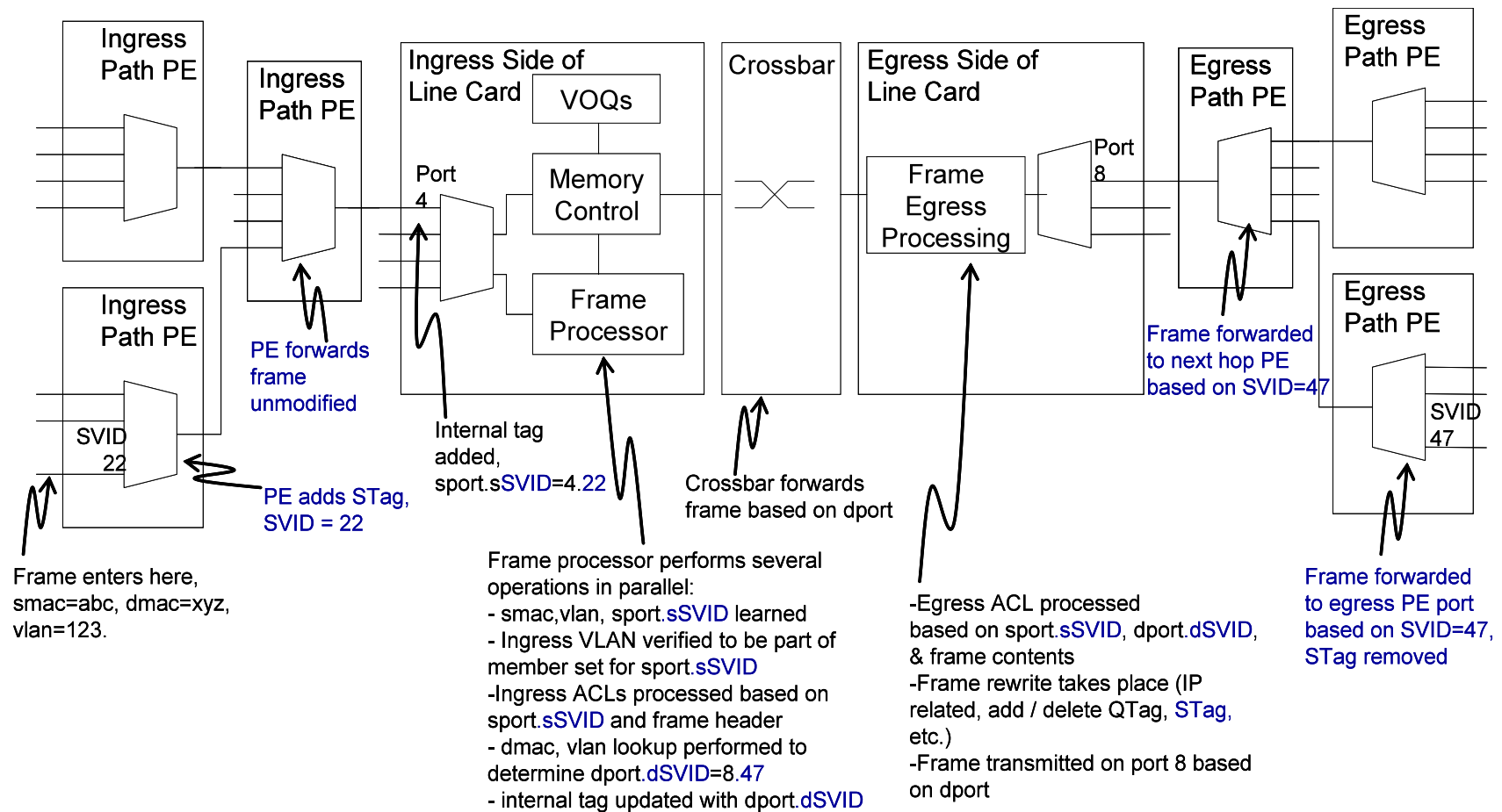

Q&A

Abbreviations

- MAC: Media Access Control. 6.2.3 of IEEE Std 802 and 6.1 of this standard.
- ISS: Internal Sublayer Service (6.6)
- LLC: Logical Link Control, 6.2.2 of IEEE Std 802 and IEEE Std 802.2 (also see 6.7 of IEEE Std 802.1AB)
- LLC-SS: LLC Sublayer Service, 6.7 of IEEE Std 802.1AB
- LLDP: Link Layer Discovery Protocol, IEEE Std 802.1AB CDCP: S-channel Discovery and Configuration Protocol (LLDP-based S-channel discovery protocol)
- EDCP: Edge Virtual Bridge Discovery and Configuration Protocol (LLDP-based EVB discovery protocol)
- ECP: Edge Control Protocol (new link layer protocol)
- ECP-SS: Edge Control Protocol Sublayer Service (new service interface for ECP to ULP)
- S-Comp: Port mapping S-VLAN component (5.10) & S-VLAN component (5.6) VEB/VEPA: C-VLAN component (5.5)

ACK	acknowledgement
CDCP	channel discovery and configuration protocol
ECP	edge control protocol
ECPDU	edge control protocol data unit
EVB	edge virtual bridging
LLDP	link layer discovery protocol
NIC	network interface controller
SCUD	S-channel user device
TLV	type, length, value
ULP	upper layer protocol
VDP	VSI discovery and configuration protocol
VEB	Virtual Ethernet Bridge
VEPA	Virtual Ethernet Port Aggregator
VTDB	VSI type database
VM	virtual machine